



(RESEARCH ARTICLE)



Development and performance evaluation of a motorized vegetables and fodder slicer using response surface methodology

Etoamaihe Ukachi Julius * and Obi Kingsley

Department of Agricultural and Bioresources Engineering, Michael Okpara University of Agriculture, Umudike, P. M. B. 7267, Umuahia, Abia State, Nigeria.

Publication history: Received on 20 July 2020; revised on 02 September 2020; accepted on 05 September 2020

Article DOI: <https://doi.org/10.30574/gjeta.2020.4.3.0043>

Abstract

A motorized vegetable and fodder slicer was designed and fabricated. The machine consists of slicing blades, feed mechanism, support frames, collector and a 1Hp gear electric motor as the driving power source. The machine has a capacity of 320kg/hr. During performance evaluation using Response Surface Methodology, it was found that the slicing efficiency increased proportionally with the speed of the machine and the moisture content of the sliced grass. The linear effects of speed of the machine and moisture content of the sliced grass significantly affected the slicing efficiency of the machine at 5% probability, ($P \leq 0.05$). The quadratic effects of the moisture content of the sliced grass and the interactions between the speed of the machine and moisture content of the sliced grass were also significant. These factors accounted for 91.06% of the variations in the slicing efficiency. The highest overall slicing efficiency of 89.57% was obtained when the moisture content of the grass material was 75% and the speed of the machine was 975rpm.

Keywords: Vegetable; Fodder; Electric Motor; Slicing; Machine; Response; Surface; Methodology

1. Introduction

Leafy vegetables and green fodders like hay are important in many Nigeria homes and they are valuable sources of nutrients, especially in rural areas where they contribute substantially to minerals, vitamins and other nutrients which are usually in short supply in daily diets of humans and livestock [1]. Green leaves and fodders play vital roles in human and livestock wellbeing. It has been established that green vegetables contribute significantly to the daily dietary requirements of Calcium (Ca) and Iron (Fe) among children within the age 2 to 5 years. Green leaves and fodders very important as they are used for maintenance of health, prevention and treatment of diseases. They contain both essential and mineral elements [2].

The population of humans and livestock in Nigeria is increasing. Nigeria has rich resources of cultivated, semi-wild and wild species of crops being used as vegetable leaves and forages which are consumed by both humans and domestic animals. Some of these vegetables are *Telfaira Occidentalis (ugu)*, *Gongronema Laifolium (utazi)*, *Solanum Melongera (anara)* and fodder like *Medicaya Sativa (alfalfa)*. Slicing of leafy vegetables and fodder reduces their sizes and exposes more of their surface areas to the atmosphere. Generally, the size of food material is often reduced during processing for many reasons, chief among which are for drying, steaming, frying or roasting. Leafy vegetables play a vital role in human wellbeing. Leafy vegetables are used to improve the quality of soup and also for their dietary purposes [3]. Nigeria has rich resources of cultivated, semi-wild and wild species of crops being used as traditional vegetables and different types are consumed by various ethnic groups for different reasons [4]. Vegetables are mostly consumed as part of a meal rather than as a whole meal. These herbaceous plants have different tastes and characteristics ranging from soft to hard, tasteless, aroma and bitterness. Herbaceous plants (soft stem) are sources of edible vegetables which

* Corresponding author: Etoamaihe Ukachi Julius
Department of Agricultural and Bioresources Engineering, Michael Okpara University of Agriculture, Umudike, P. M. B. 7267, Umuahia, Abia State, Nigeria.

are rich in nutrients. Vegetables constitute important component of a balanced diet for man. The green leafy vegetables are rich in protein, minerals, carbohydrate, calcium, iron, phosphorus and all vitamins [5].

Slicing is a form of size reduction and the general term “size reduction” includes slicing, cutting, crushing, chopping, grinding and milling. The reduction in size is brought about by mechanical means without change in chemical properties of the material. It brings about uniformity in size and shape of individual units of the end product. Such processes as cutting of fruits or vegetables for canning, shredding sweet potatoes for drying, slicing onion for salad, chopping corn fodder, grinding grain for livestock feed and milling flour are size reduction operations. Reducing the size of food raw materials is an important operation to achieve a definite size range [6].

The traditional or manual method of slicing vegetables with knives are time consuming and unhygienic, moreover the slices produced are not usually uniform. The drudgery associated with the manual method is another disadvantage especially when processing large quantities of products [7].

Size reduction may help in the extraction of desirable constituents from raw materials e.g. crushing palm fruits for extraction of palm oil, milling grains for the production of flour, crushing fruits for juice or for fermentation. Some other operations in food processing and preservation are facilitated by smaller sized particles, for examples, when a food material such as yam is to be dried, it is cut into slices to expose more surface area to the drying medium. Similarly, in drying of *okro* or tomatoes, the vegetables and fruits are sliced into smaller pieces to facilitate heat transfer and removal of moisture from the pieces, [7].

Majority of the existing slicing machines are imported, expensive and sophisticated and are not easy to operate and maintain by the local users. Also, some of these machines are designed for crops like onions, tomato, and potato *etc.* and cannot be used for vegetable leaves such as grass (*achara*), fluted pumpkin leaf and fodders *etc.* Hence the imperative for the development of this machine.

2. Material and methods

2.1. Design consideration

The following factors were considered in designing the slicer:

- To develop a machine that can slice vegetables and fodder smoothly and uniformly.
- Develop a machine that is smooth in operation with little noise.
- To use locally available materials for its construction.
- To develop a rigid and reliable machine when in operation.

2.2. Machine description

The machine consists of the following major components; the frames, the feeding chute, slicing blades in an enclosure, the gear electric motor, the shaft and the collector.

A detailed drawing of the machine, showing the isometric and orthographic views are presented in Figures 1 and 2, while a picture of the fabricated machine is shown in Fig 3. During operations, the vegetable material is fed manually through the chute into the slicing chamber, where rotating slicing blades slice them. The slicing blades derive their power through a rotating shaft powered by a 1Hp gear electric motor. The slicing blades are covered by a rectangular metal chamber to prevent the sliced materials from flying away. The enclosure has an opening beneath it where the sliced materials are discharged into a collector.

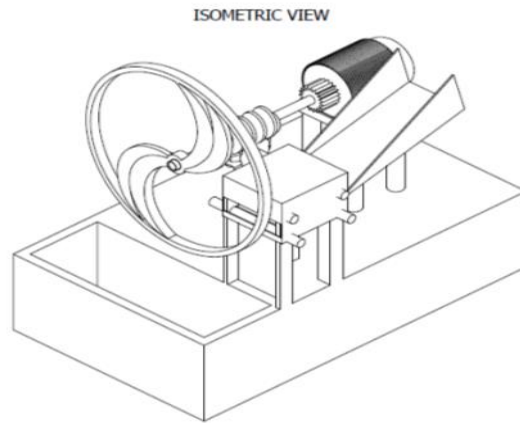

Figure 1 Isometric drawing of the vegetable /fodder slicer

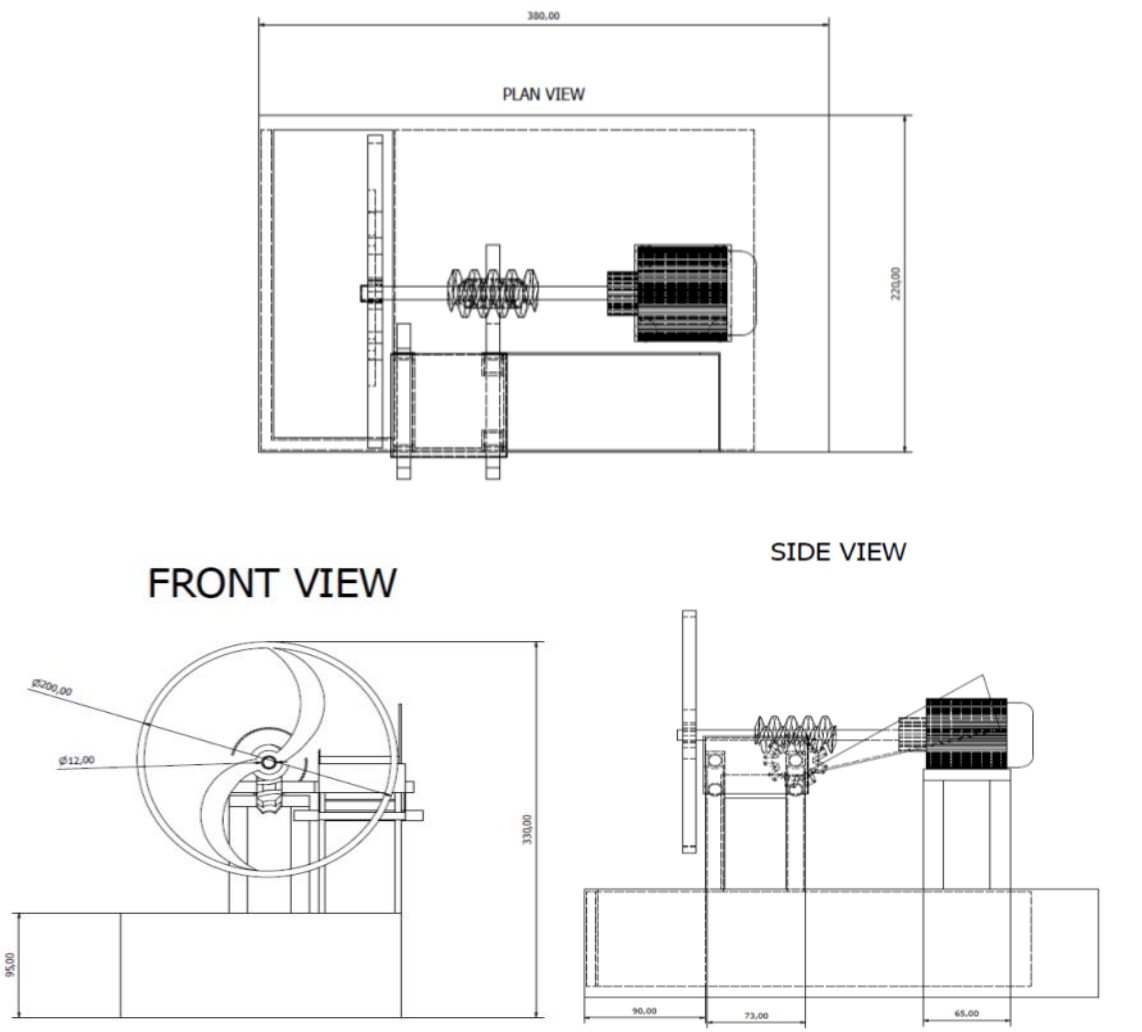

Figure 2 Orthographic drawing of the vegetable /fodder slicer



Figure 3 Picture of the developed vegetable/fodder slicer

2.3. Design analysis and calculations

The disc cutting blade is primary component that does the slicing. Some basic empirical properties were determined as shown below;

Speed of rotation of disc blade – it is determined by using the equation by [8] as:

$$v = \omega r \quad (1)$$

Where

v = Linear velocity (m/s)

ω = Angular Velocity ($rad. s^{-1}$)

r = Radial length of disc blade (selected) = 130 mm

The angular velocity is expressed as;

$$\omega = \frac{2\pi N}{60} \quad (2)$$

Where

N = Number of revolution per minutes ($N = 1000$ rpm)

2.4. The Power drive mechanism

The power is from electric motor and the power required by the cutting disc was calculated using the relation by [8];

$$P = \tau \omega \quad (3)$$

Where

P = power required (hp)

τ = Torque (Nm)

And the torque is calculated from the equation

$$\tau = Fr \quad (4)$$

F = forced required for the slicing

(i.e 1.121N as recommended by [9].)

r = Radial length of the slicer blade.

A 1Hp electric motor was selected because of the estimated power requirements for slicing.

Total kinetic energy stored on the disc blade is calculated by the following equation

$$K.E. = \frac{1}{2} I \omega^2 \quad (5)$$

I = Moment of inertia (kgm²)

$$I = W_d R^2 \quad (6)$$

And

$$W = \pi R^2 t \rho \quad (7)$$

Where

W = weight of the slicing disc blade (kg)

R = radial length of the slicing blade (m)

t = thickness of the blade (2mm)

ρ = density of the mild steel blade material (7850kg/m³)

2.5. Slicer drive shaft diameter

The drive shaft diameter was obtained using the expression outlined by [10] and is given as;

$$d^3 = \frac{16}{\pi \tau_{\max}} \sqrt{(M_b K_b)^2 + (M_t K_t)^2} \quad (8)$$

Where,

Mt = torsional moment (136.05Nm)

Kb = combined shock and fatigue factors applied to bending

Kt = combined shock and fatigue factors applied to torsional moment

Mb = bending moment

τ_{max} = allowable shear stress of mild steel.(40MN/m²)

The diameter of the slicer blade shaft was obtained as 25mm

2.6. Bearing selection

Using the expression by [11], the radial load acting on the drive shaft is obtained as

$$F = \frac{19.1PK \times 10^6}{D S} \quad (9)$$

Where, F is the radial force on the shaft (N), P, the power transmitted (kW), D is the diameter of the drive shaft

2.7. The frames

The frames are made of 3mm thick mild steel bars and have the following dimensions; 930mm x 470mm x 650mm for length x breadth x height respectively.

2.8. Capacity of the machine

This was obtained using the expression by [12] as:

$$C = \frac{Q}{t} \quad (10)$$

Where C = capacity of the machine (kg/hr), Q = weight of sliced materials (kg), t= time taken to slice the material (hr). This was experimentally obtained as 320kg/hr.

After the design, the machine was fabricated at National Root Crop Research Institute Umudike Engineering workshop. Special efforts were made to adhere strictly to the design specifications during the fabrication.

3. Results and discussion

After the fabrication of the machine its operational performance was evaluated. A faced centred response surface methodology using central composite design was used to design the experiments. This method is useful because it uses very few experimental runs to describe how the test variables affect the response. It also helps to determine the inter-relationships among the test variables on the response and also helps to describe the combined effects of all the test variables on the response ([13], [14]). In the tests, three factors, namely speed of the machine, the number of slicing blades and the moisture contents of alfalfa grass samples (materials sliced in the experiments) were investigated as they affected the slicing efficiency of the machine. The regression analysis was carried out with Minitab 16 software, while the response surface graphs were plotted with Matlab R2015a software.

3.1. Slicing efficiency

The slicing efficiency is the amount of alfalfa grass sliced per total amount of alfalfa grass fed into the machine. The mathematical expression for slicing efficiency as used by [15] is:

$$SE = \frac{M_2 - M_1}{M_1} \times 100\% \quad (11)$$

Where: SE =Slicing efficiency (%); M_2 = total mass fed into the machine (gm); M_1 = Total mass unsliced (gm)

3.2. Moisture content

The moisture content of the alfalfa grass is the amount of moisture content in percent contained in a given weight of alfalfa grass. This can be obtained either on dry or wet basis form. For this experiment the wet basis form (gravimetric method) was used and it is expressed by [15] as follows;

$$M_{cwb} = \frac{M_w}{M_d + M_w} \times 100\% \quad (12)$$

Where ; M_{cwb} =Moisture content on wet basis; M_w = Mass of moisture in the grass (gm)

M_d = Mass of bone dried alfalfa grass

The moisture content of the alfalfa grass was varied by oven drying. Constant testing of the drying alfalfa grass with a moisture meter was done until the desired moisture content level was achieved and the specimen was brought out for slicing with the developed machine. The readings obtained from the moisture meter tallied with those obtained through the gravimetric methods.

In the design the linear, interactive and quadratic effects of the factors (independent variables) as they affect the response (chipping efficiency) were studied. Three levels of each of the factors were studied. They are listed as follows;

Three different speeds of the machine, namely;

- (a) 325rpm (b) 650rpm (c) 975 rpm

Three different numbers of slicing blades, namely;

- (a) 2 blades (b) 4 blades (c) 6 blades

Moisture content levels of Alfalfa grass, namely;

- (a) 45% (b) 60% (c) 75%

The experimental variables and coding are shown in Table 1, while the experimental results with the independent variables (in coded terms) are shown in Table 2. The estimated regression coefficients for slicing efficiency versus speed of the machine, number of blades and moisture content of grass material are shown in Table 3, while the analysis of variance associated with the regression are shown in Table 4.

Table 1 Experimental variables used in the design

Independent Variables	Variable Levels		
Speed of machine (rpm), X1	975	650	325
Number of Slicing Blades X2	2	4	6
Moisture Content of Grass(%) X3	45	60	75
Code Designation	1	0	-1
Dependent Variable (Response)			
Slicing Efficiency (%) Y			

The coding using the design is as follows; 1 = highest factor, 0 = medium factor and -1 =lowest factor

Table 2 Experimental results of independent variables and response in coded terms

Runs	X1	X2	X3	Y
1	1	-1	1	90
2	0	0	0	82
3	-1	-1	-1	80
4	0	1	0	81
5	0	0	0	79
6	1	1	1	92
7	0	0	0	78
8	-1	1	-1	78
9	0	-1	0	80
10	-1	1	1	81
11	0	0	0	80
12	0	0	0	79
13	0	0	0	79
14	-1	0	0	79
15	0	0	-1	81
16	1	-1	-1	83
17	-1	-1	1	82
18	1	0	0	81
19	0	0	1	84
20	1	1	-1	81

Results from Table 3, showed that the linear effects of speed of the machine and the linear effect of the moisture content of the grass material significantly affected the slicing efficiency of the machine at 5% probability, ($P \leq 0.05$). Also significant in the tests are quadratic effects of the moisture content of grass material and the interactions between the speed of the machine and the moisture content of the grass material used in the tests. These factors accounted for 91.06 % of the variation in the slicing efficiency of the machine. The analysis of variance Table 4 also confirms the results. From the response surface graph in Fig.4, the slicing efficiency increased with the moisture content of the grass material and the speed of the machine, with highest overall slicing efficiency of 89.57% obtained when the moisture content of the grass material was 75% and the speed of the machine was 975rpm. In Fig. 5, the slicing efficiency increased with the number of the slicing blades and the speed of the machine, with a maximum value of 83.52% when the speed of the machine was 975rpm and number of slicing blades were 6. From Fig. 6, the highest efficiency of 86.16% was obtained when the moisture content was 75% and number of slicing blades were 6.

Table 3 Response surface regression: Y versus X1, X2, X3

Term	Coef	SE Coef	T	P
Constant	79.5909	0.5130	155.140	0.000
X1	2.7000	0.4719	5.721	0.000
X2	-0.2000	0.4719	-0.424	0.681
X3	2.6000	0.4719	5.509	0.000
X1*X1	0.2727	0.8999	0.303	0.768
X2*X2	0.7727	0.8999	0.859	0.411
X3*X3	2.7727	0.8999	3.081	0.012
X1*X2	0.3750	0.5276	0.711	0.493
X1*X3	1.6250	0.5276	3.080	0.012
X2*X3	0.6250	0.5276	1.185	0.264

S = 1.49233; R-Sq = 91.06%

Table 4 Analysis of variance for Y

Source	DF	Seq SS	Adj	SS	Adj	MS
Regression	9	226.730	226.730	25.1922	11.31	0.000
Linear	3	140.900	140.900	46.9667	21.09	0.000
X1	1	72.900	72.900	72.9000	32.73	0.000
X2	1	0.400	0.400	0.4000	0.18	0.681
X3	1	67.600	67.600	67.6000	30.35	0.000
Square	3	60.455	60.455	20.1515	9.05	0.003
X1*X1	1	28.800	0.205	0.2045	0.09	0.768
X2*X2	1	10.513	1.642	1.6420	0.74	0.411
X3*X3	1	21.142	21.142	21.1420	9.49	0.012
Interaction	3	25.375	25.375	8.4583	3.80	0.047
X1*X2	1	1.125	1.125	1.1250	0.51	0.493
X1*X3	1	21.125	21.125	21.1250	9.49	0.012
X2*X3	1	3.125	3.125	3.1250	1.40	0.264
Residual Error	10	22.270	22.270	2.2270		
Lack-of-Fit	5	12.770	12.770	2.5541	1.34	0.377
Pure Error	5	9.500	9.500	1.9000		
Total	19	249.000				

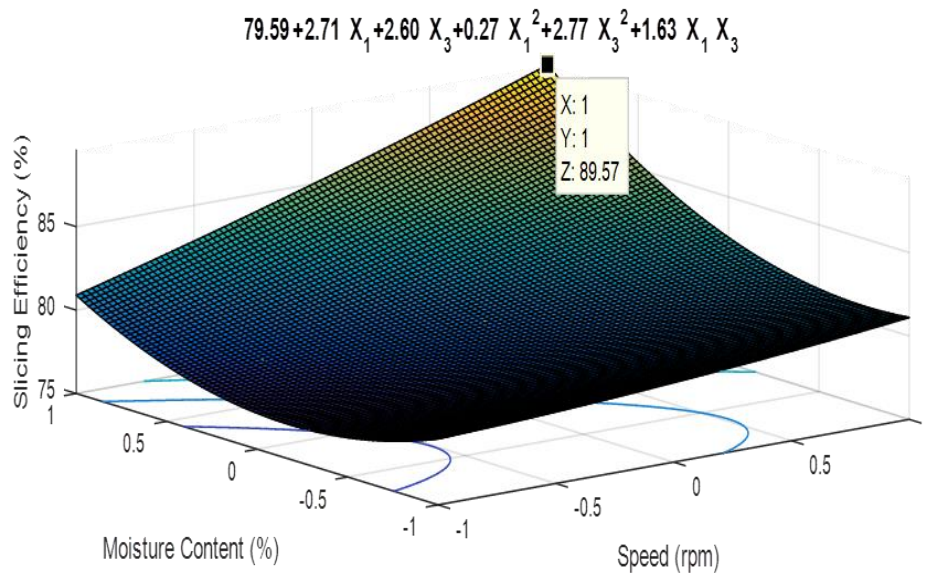

Figure 4 Response surface curve of the effects of moisture content of grass and speed of machine on the slicing efficiency of the machine.

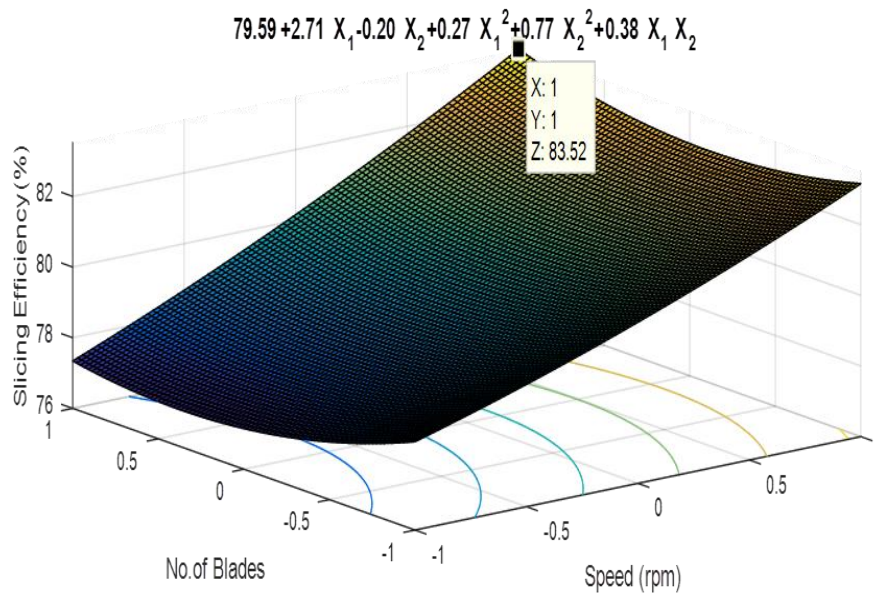

Figure 5 Response surface curve of the effects of number of slicing blades and speed of machine on the slicing efficiency of the machine.

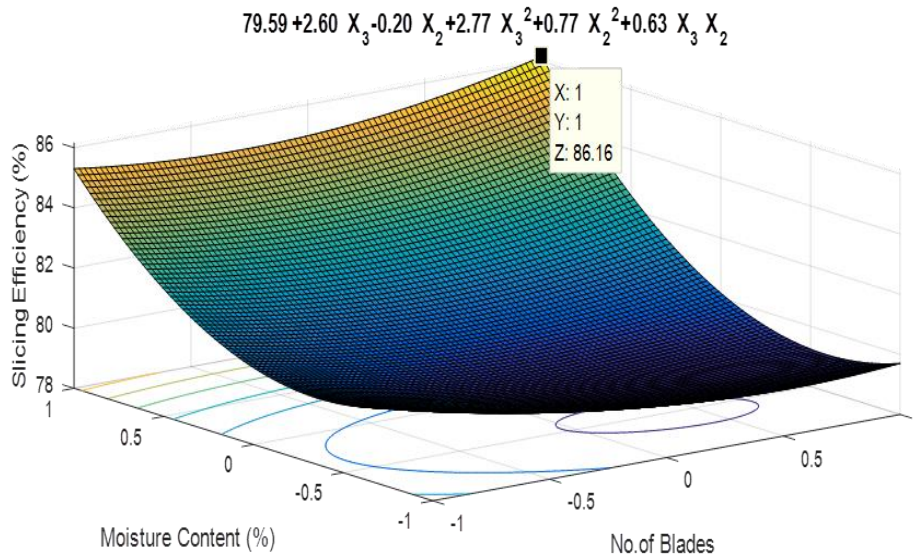

Figure 6 Response surface curve of the effects of moisture content of grass and number of slicing blades on the slicing efficiency of the machine.

4. Conclusion

The machine performed satisfactorily well during tests. It was observed that the machine was able to slice a variety of vegetables and fodder uniformly into smaller units. It also maintained good ergonomic characteristics in terms of noise and vibrations during operations. It was observed that the linear effects of speed of the machine and the linear effects of the moisture content of the grass material significantly affected the slicing efficiency of the machine at 5% probability, ($P \leq 0.05$). Also significant in the tests are quadratic effects of the moisture content of grass material and the interactions between the speed of the machine and the moisture content of the grass material used in the tests. These factors accounted for 91.06 % of the variation in the slicing efficiency of the machine. The slicing efficiency increased proportionally with the moisture content of the grass and the speed of slicing blades, with an overall highest slicing efficiency obtained when the moisture content of grass was 75% and the speed of the slicing blades were 975rpm.

Compliance with ethical standards

Acknowledgments

We wish to acknowledge the assistance of the former Head of Department of Agricultural and Bioresources Engineering Prof A.B. Ekeh, for giving us permission to use his Processing Laboratory to carry out this research work. We also wish to thank the Chief technologist in the Engineering workshop, Okafor Yadi for his immense assistance during the research period.

Disclosure of conflict of interest

We (Etoamaihe Ukachi Julius and Obi Kingsley) the authors of the article "Development and performance evaluation of vegetable/fodder slicer using response surface methodology" wish to state that there are no conflicts of interests in this our research article.

References

- [1] Okon OG and James US. (2014). Proximate and mineral composition of some traditional vegetables in Akwa Ibom State Nigeria. International journal of scientific and research publications, 4(8), 1-3.
- [2] D'Mello JP. (2003). Food safety: contaminants and toxins. Cabi publishers, Wallingford UK, 120-205.
- [3] Moshia TC and Gaga HE. (1999). Nutritive value and effect of blanching on the trypsin and chymotrypsin inhibitor activities of selected leafy vegetables. Plant foods for human nutrition, 54, 279-283.

- [4] Eroarome MA. (2012). Nutritive value and inherent anti-nutritive factors in four indigenous edible leafy vegetables in human nutrition in Nigeria: A Review. *Journal of food resource science*, 1(1), 1-14.
- [5] Kordylas JM. (1991). *Processing and preservation of tropical and sub-tropical foods*. Macmillan education limited, 78-94.
- [6] Henderson SM and Perry RL. (1980). *Agricultural processing engineering*. Third edition. Macmillan publishing company, New York, 185.
- [7] Raji OA and Igbeka JC. (1994). Pedal operated chipping and slicing machine for tuber. *Journal of agricultural engineering technology*, 2, 90 - 99.
- [8] Khurmi RS and Gupta JK. (2005). *A Textbook of machine design*, 14th Edition, Eurasia publishing house (PVT.) Ltd. Ram Nagar, New Delhi, 456-498.
- [9] Ogbobe PO, Ugwuishiwu BO, Orishagbemi CO and Ani AO. (2007). Design, construction and evaluation of motorized okra slicer. *Nigerian journal of technology*, 26(2), 42-49.
- [10] Singh S. (2001). *Machine Design*. Khanna Publishers, New Delhi, 298-333.
- [11] Krutz G, Thompson L and Claar T. (1984). *Design of agricultural machinery*. John Wiley and New York, 259-277.
- [12] Ahemen SA and Raji AO. (2008). Development and performance evaluation of a motorized rasping machine for *Tacca Involucrata*. *Journal of agricultural engineering and technology (JAET)*, 16(1), 52-63.
- [13] Khuri AI and Cornell JA. (1996). *Response surfaces*. 2nd Edition Dekker, New York
- [14] Agriga AN and Iwe MO. (2008). Physical properties of cookies produced from cassava, groundnut-corn starch blend. A response surface analysis. *Nigerian food journal*, 26(2), 83-96.
- [15] Oyelade OA and Olaoye OJ. (2013). Performance evaluation of a slider crank based sugarcane Juice extractor. *Journal of agricultural engineering and technology (JAET)*, 21(2), 21-30.